

ADDENDUM NO. 1

TO: ALL PLAN HOLDERS

RE: CITY OF EMERSON, ARKANSAS
WALKING TRAIL IMPROVEMENTS

DATE: January 15, 2025

The Plans, Specifications and Contract Documents for the above referenced project are hereby modified as follows:

1. **Bid Proposal Update: Remove and Replace the bid proposal with the attached.**
2. **Add Appendix A to the end of the Technical Specifications. See the attached.**
3. **Plan Sheet Updated: See the update plan sheets 3 &4.**

ADDENDUM NO. 1 ISSUED BY:

A.L. FRANKS ENGINEERING

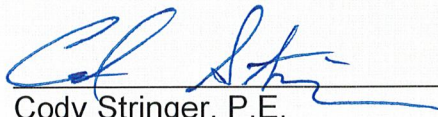

Cody Stringer, P.E.
Project Manager



CITY OF EMERSON, ARKANSAS
HENDRIX COMPLEX PARK IMPROVEMENTS 50/50 MATCHING GRANT

BID PROPOSAL

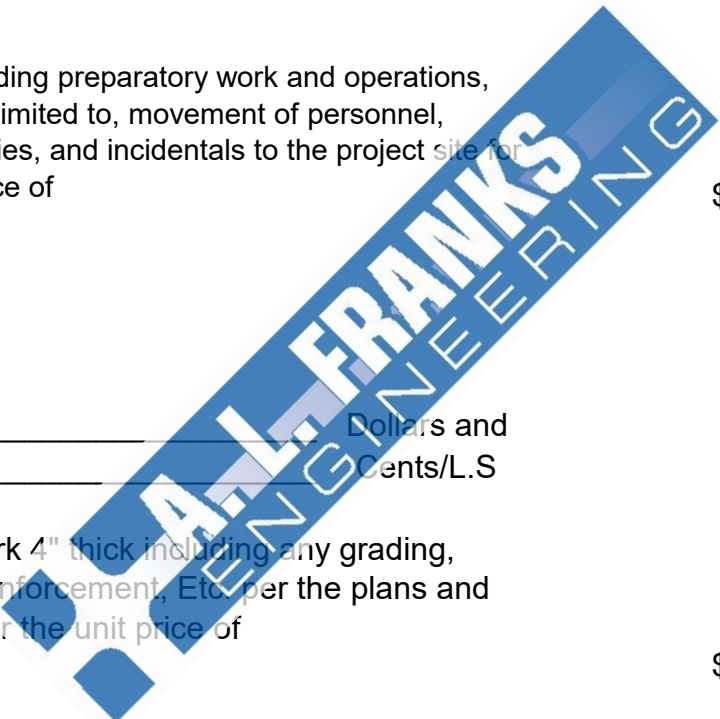
ITEM	QTY	UNIT	DESCRIPTION	UNIT PRICE	TOTAL PRICE
1	1	L.S.	Mobilization including preparatory work and operations, including but not limited to, movement of personnel, equipment, supplies, and incidentals to the project site for the lump sum price of	\$ _____	\$ _____
			_____ Dollars and _____ Cents/L.S		
2	3960	S.F.	Concrete flatwork 4" thick including any grading, paving sand, reinforcement, Etc. per the plans and specifications for the unit price of	\$ _____	\$ _____
			_____ Dollars and _____ Cents/S.F.		



BID PROPOSAL CONTINUED

ITEM	QTY	UNIT	DESCRIPTION	UNIT PRICE	TOTAL PRICE
3	1	L.S.	Provide concrete Handicap Accessible Parking to include sidewalk access for a (25' X 38' area) parking area including striping and parking curb stop per plans and specifications for the unit price of _____ Dollars and _____ Cents/L.S.	\$ _____	\$ _____
4	2	E.A.	Provide and install Pipe Bollards per the plans and specifications for the unit price of _____ Dollars and _____ Cents/E.A.	\$ _____	\$ _____

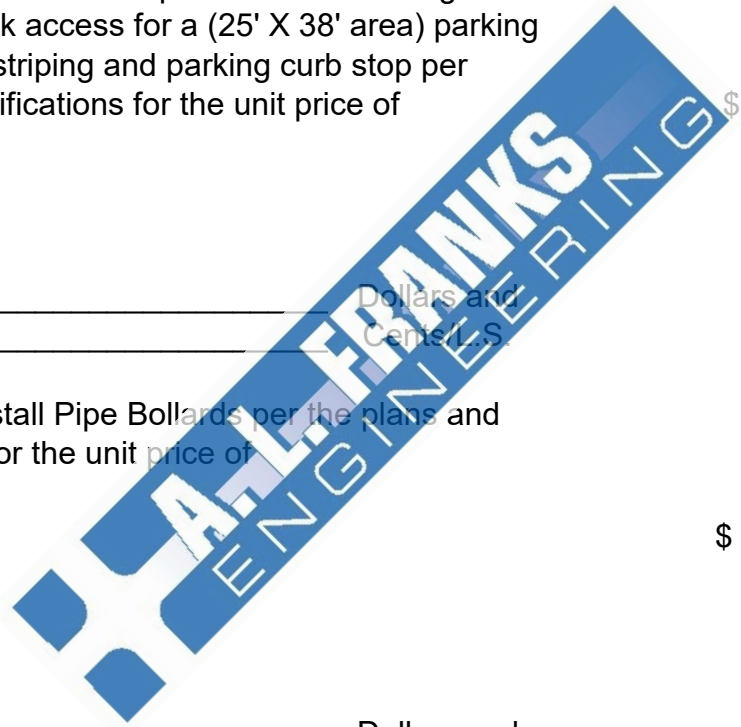

BID PROPOSAL CONTINUED

ITEM	QTY	UNIT	DESCRIPTION	UNIT PRICE	TOTAL PRICE
5	2	E.A.	Furnish and Install 108" x 48" Concrete flatwork 4" thick including bench, mounting the bench, any grading, paving sand, reinforcement, and other incidental items as required for a complete and functional walkway per the plans and specifications for the unit price of _____ _____ Dollars and Cents/E.A.	\$ _____	\$ _____
6	6,600	S.F.	Grade and Seed sidewalk per plans and specification for the unit price of _____ _____ Dollars and Cents/S.F.	\$ _____	\$ _____

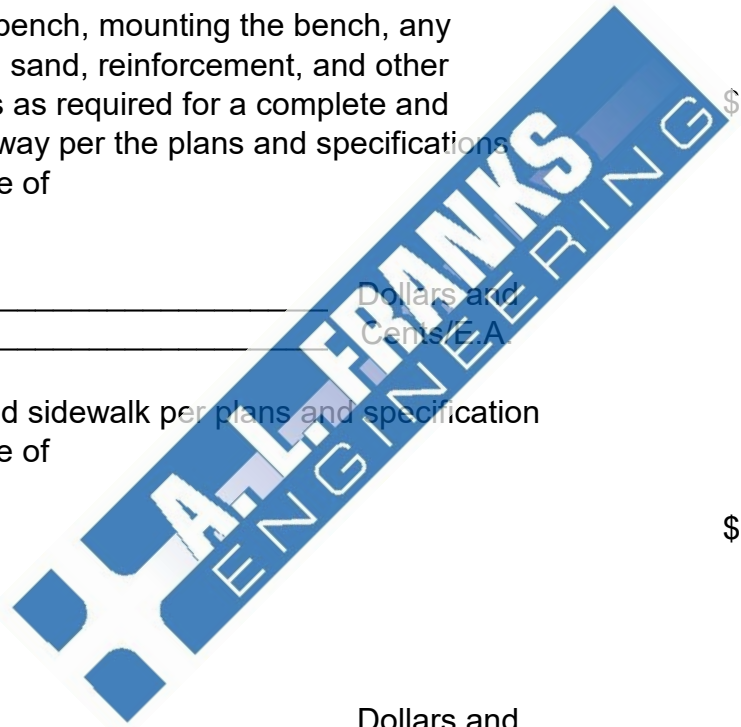

BID PROPOSAL CONTINUED

TOTAL OF ALL ITEMS

\$

NOTES:

- 1) Submission of the completed Bid Proposal is considered evidence to the Owner that the Contractor fully and clearly understands the complete scope of work and all actions and materials required to complete the work.
- 2) Items required but not specifically called out in the Bid Proposal shall be included in other items.
- 3) Time required to complete work shall be 120 calendar days.

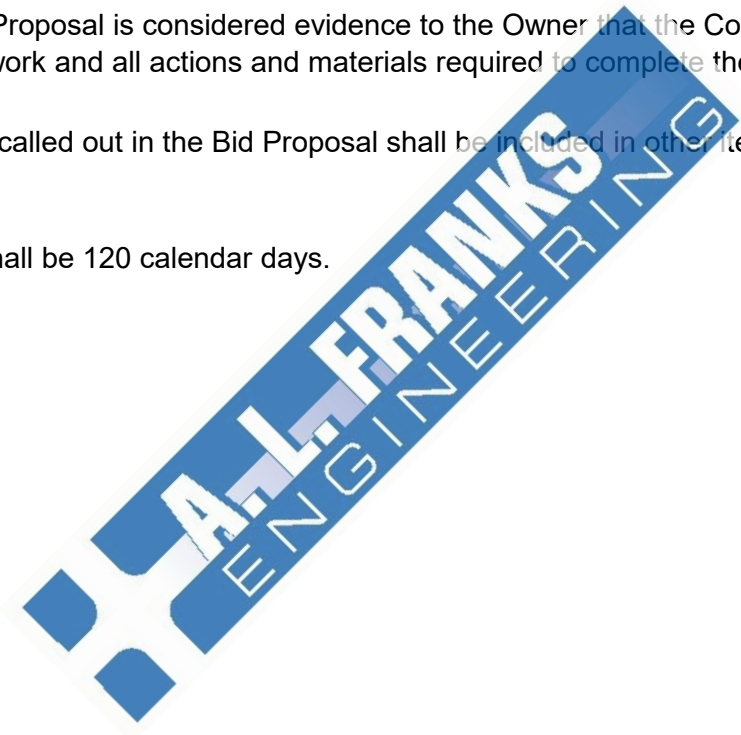



APPENDIX A

2-3/8" O.D. FRAME BENCHES

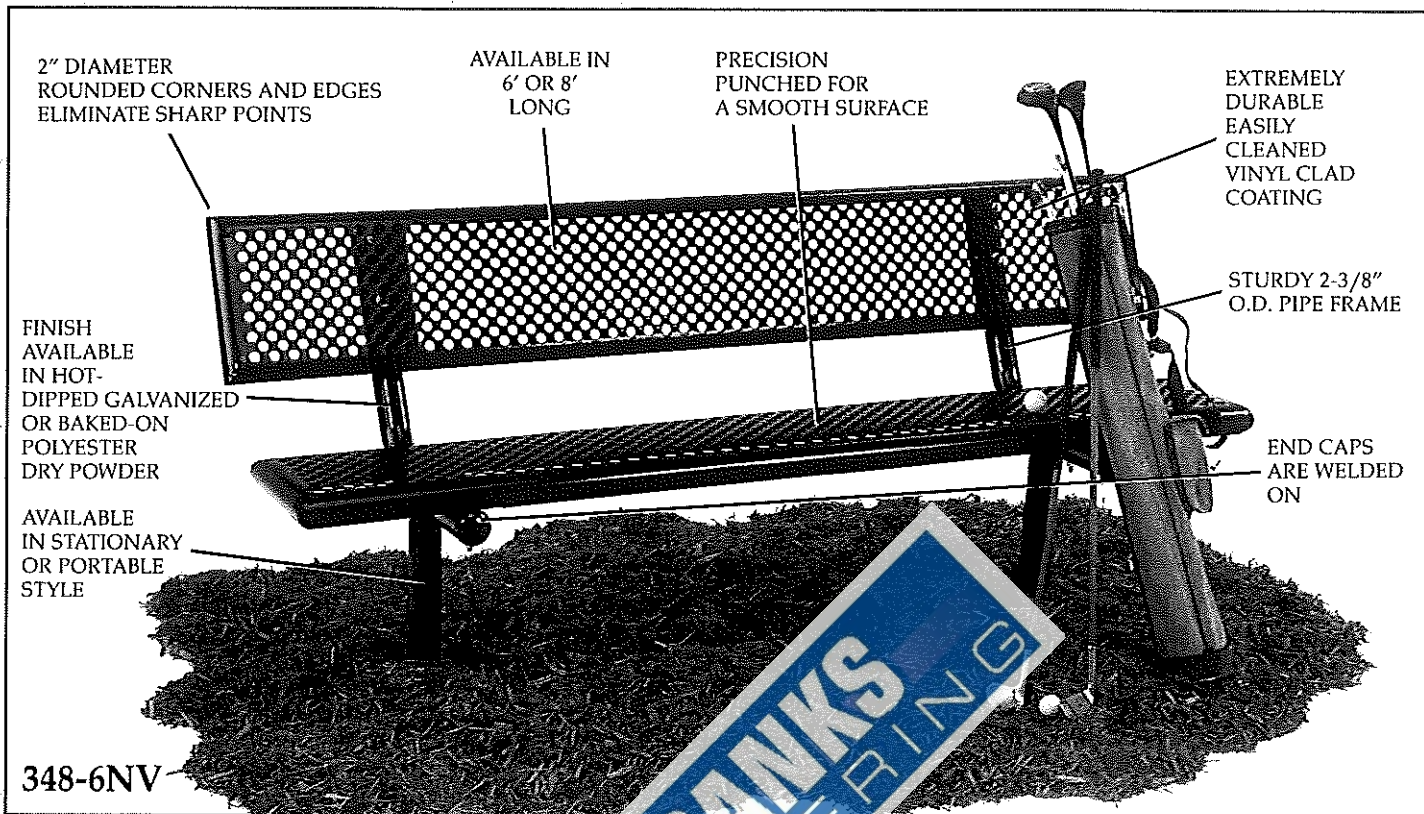

348-6NV

Frames Only

338-G	6' or 8' long, stationary, galvanized, frame only	33 lbs.
338-N	6' or 8' long, stationary, painted brown*, frame only	33 lbs.
339-G	6' or 8' long, portable, galvanized, frame only	41 lbs.
339-N	6' or 8' long, portable, painted brown*, frame only	41 lbs.

Vinyl Clad Top and Seats

348-6GV	6' long, stationary, galvanized, vinyl clad top and seats	116 lbs.
348-6NV	6' long, stationary, painted brown*, vinyl clad top and seats	116 lbs.
348-8GV	8' long, stationary, galvanized, vinyl clad top and seats	136 lbs.
348-8NV	8' long, stationary, painted brown*, vinyl clad top and seats	136 lbs.
349-6GV	6' long, portable, galvanized, vinyl clad top and seats	122 lbs.
349-6NV	6' long, portable, painted brown*, vinyl clad top and seats	122 lbs.
349-8GV	8' long, portable, galvanized, vinyl clad top and seats	143 lbs.
349-8NV	8' long, portable, painted brown*, vinyl clad top and seats	143 lbs.

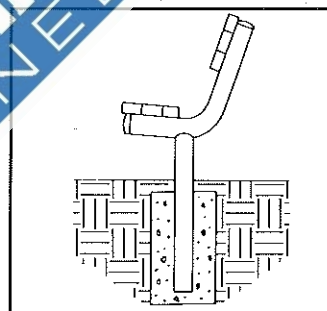

Model 338 and 348 (Stationary)

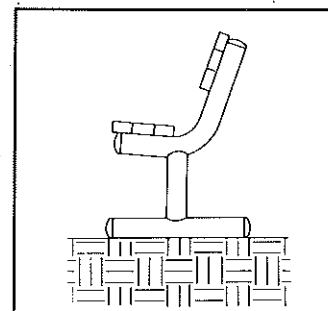

Model 339 and 349 (Portable)

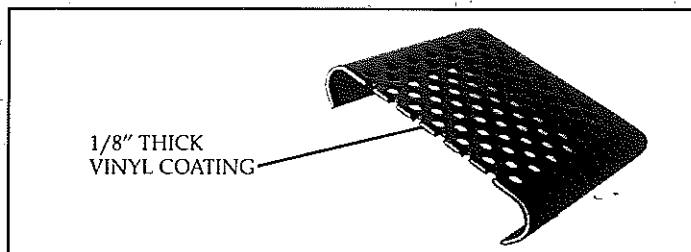

1/8" THICK VINYL COATING

Models 339 & 349

Overall dimensions shall be 33" high x 21" wide x 6' (or 8') long; Average seat height above ground shall be 18". Park bench frames shall have an 11-1/2" vertical leg welded to a 23" horizontal foot and a 1-5/16" O.D. galvanized cross brace shall be attached to the base of each leg and to bottom of seat. All frames shall be fabricated from 2-3/8" O.D. galvanized iron pipe. Galvanized stamped steel end caps shall cover open pipe ends. All frame components shall be electrically welded together such that sharp corners and edges are eliminated.

Finish

Painted finish also available. Standard painted finish is electrostatically applied, baked-on, polyester dry powder, available in brown, black or green. Please specify Y for green, X for black, and N for brown in the model number.

SPECIFICATIONS

Models 338 & 348

Overall dimensions shall be 33" high x 21" wide x 6' (or 8') long. Average seat height above ground shall be 18". Park bench frames shall have a vertical 36" leg, to be embedded in concrete: All frames shall be fabricated from 2-3/8" O.D. galvanized iron pipe. Galvanized stamped steel end caps shall cover open pipe ends. All frame components shall be electrically welded together such that sharp corners and edges are eliminated.

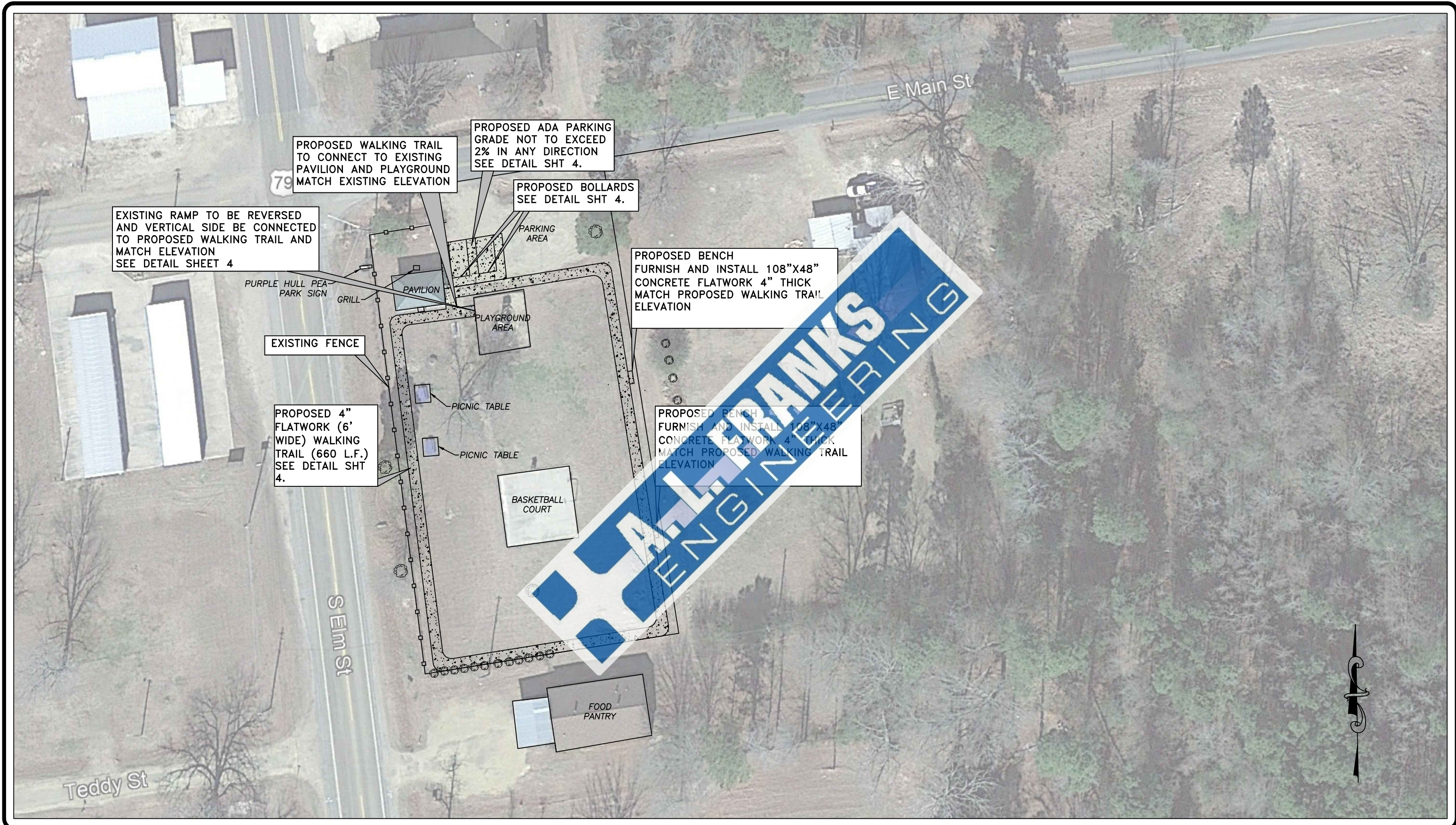

Date	Revision	By

Designed DJL
 Checked CJS
 Drawn DJL
 Approved ALF

A.L. FRANKS ENGINEERING
 118 East Broad Street
 Texarkana, Arkansas 71854
 Phone (870) 216-1906
 Fax (870) 216-1907

102 N HAZEL ST.
 EMERSON, ARKANSAS 71740
 PHONE: 870-547-2220

CITY OF EMERSON, ARKANSAS
 PARK / TRAIL IMPROVEMENTS
 PROPOSED SITE PLAN

STATE OF ARKANSAS
 LICENSED PROFESSIONAL ENGINEER
 No. 21958
 CODY S. STRONG

Job No.: EM-01-24
 Scale: 1"=50'
 Date: 9/2024
 Sheet 3

TYPICAL SIDEWALK NOTES:

1. ALL CONCRETE SIDEWALK PAVING TO HAVE A SINGLE MAT OF REINFORCING STEEL (NO. 4 BARS 18" OCEW)
2. ALL SIDEWALK TO HAVE CONTROL JOINTS AT INTERVALS EQUAL TO THE SECTION WIDTH.
3. ALL SIDEWALK TO HAVE EXPANSION JOINTS AT INTERVALS NOT TO EXCEED 80'.

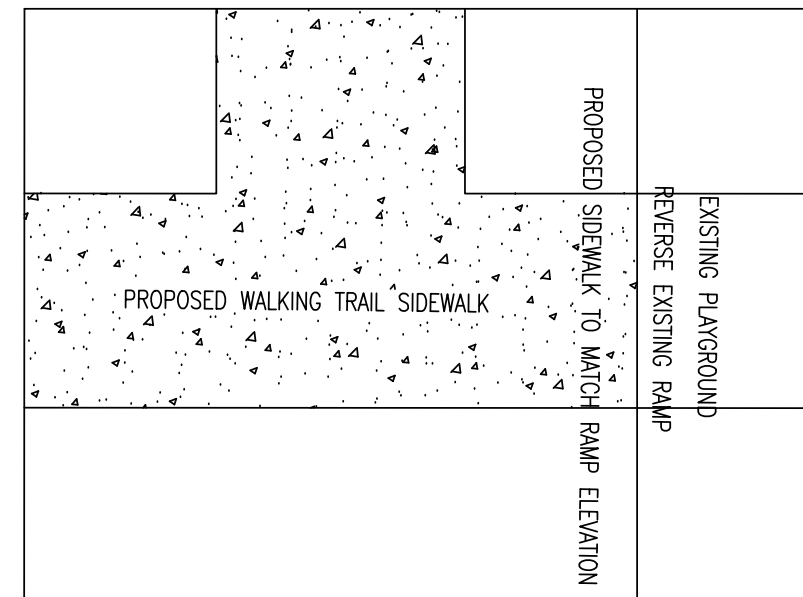
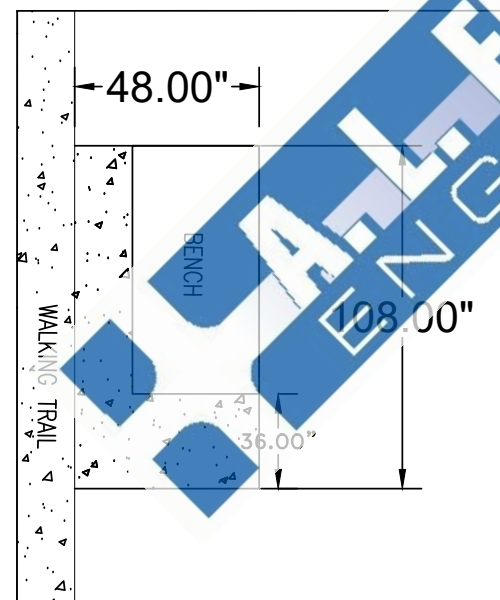
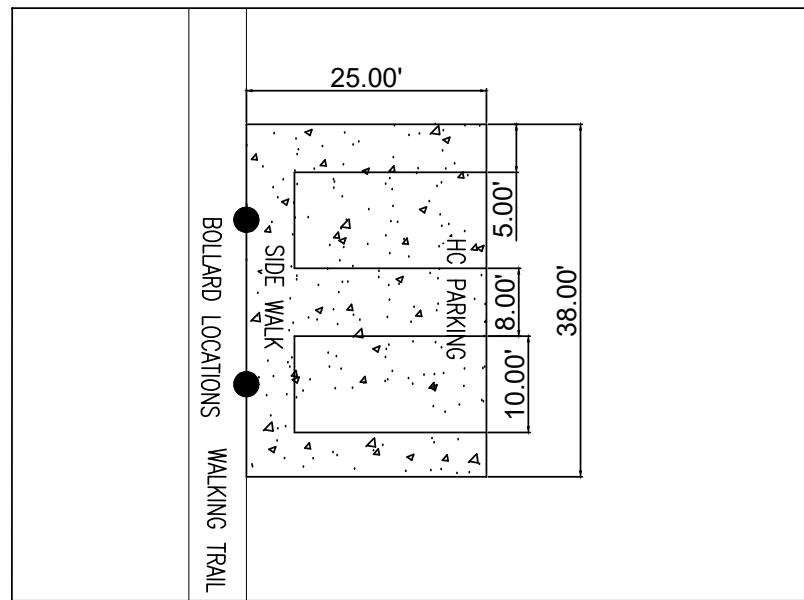
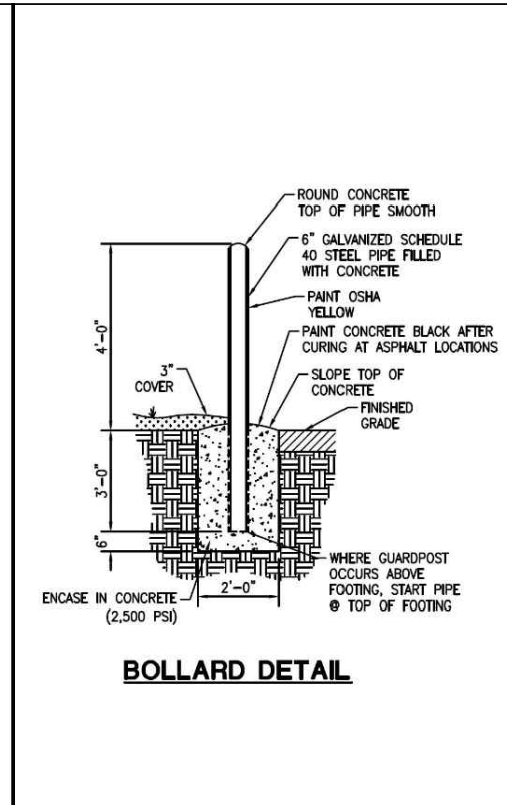
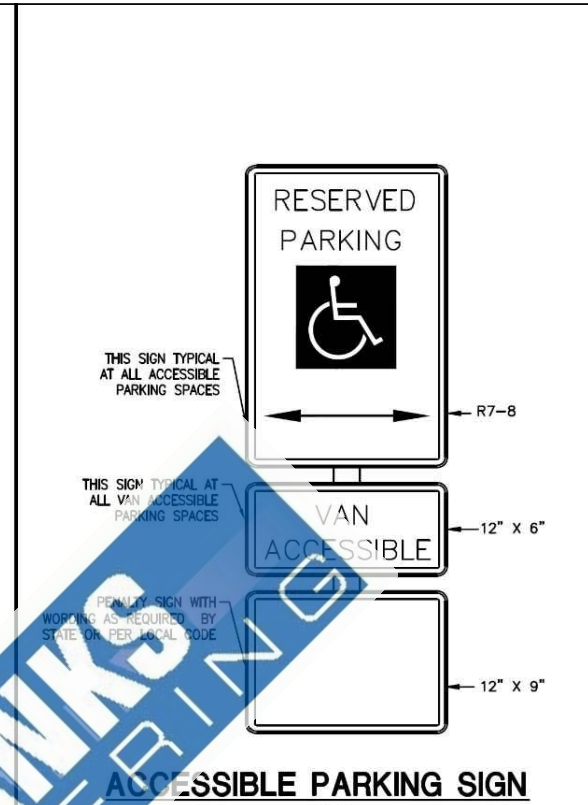
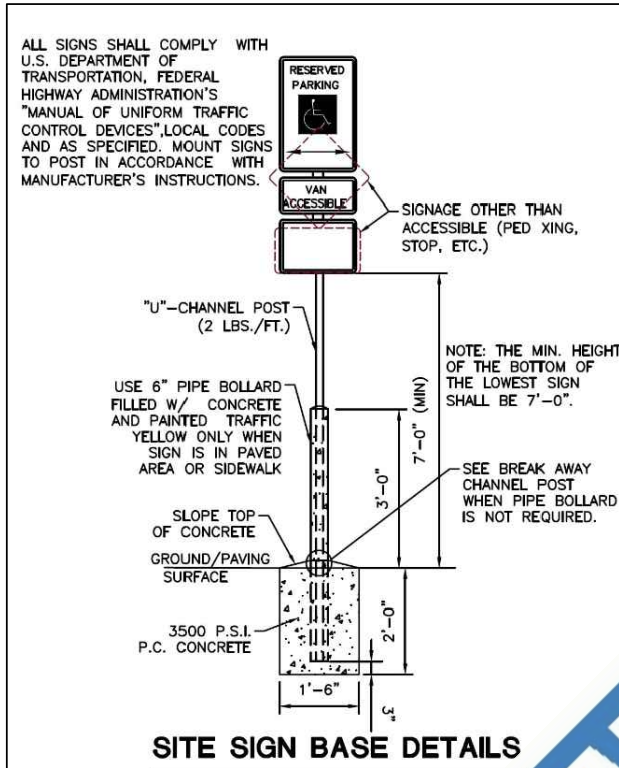
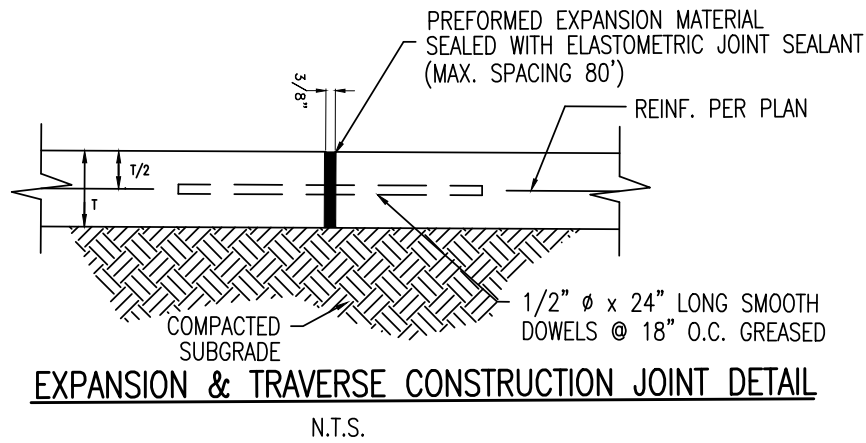

- TYPICAL ADA PARKING NOTES:
1. GRADE OF CONCRETE PAD NOT TO EXCEED 2% GRADE IN ANY DIRECTION

Date	Revision	By

Designed	DJL
Checked	CJS
Drawn	DJL
Approved	ALF

118 East Broad Street
Texarkana, Arkansas 71854
Phone (870) 216-1906
Fax (870) 216-1907

102 N HAZEL ST.
EMERSON, ARKANSAS 71740
PHONE: 870-547-2220

CITY OF EMERSON, ARKANSAS
PARK / TRAIL IMPROVEMENTS
PROPOSED SITE PLAN

Job No.: EM-01-24
Scale: 1"=50'
Date: 9/2024
Sheet 4